



\$P16190001\$Hpicking

10

Pose équerre four

SOKLEO OSKAB® POUR TOUS

Les outils

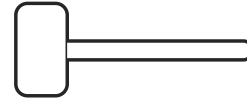
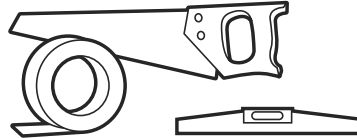
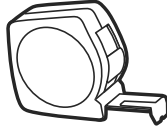
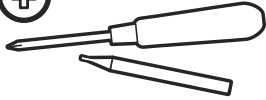

• Sachet équerre four

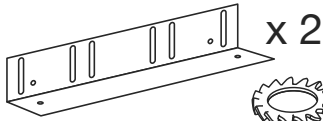

x 2



x 4

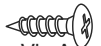

Vis A

x 4

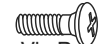

Vis B

x 4

• Sachet n°10



x 2



Pivot

x 2

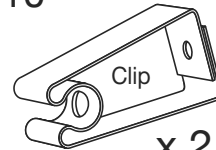

x 2



1 personne



20 mm

Etape 1

Déterminer l'emplacement des équerres.

Mesurer la hauteur totale du four (A) et la reporter sur le côté du caisson en ajoutant 2 mm.

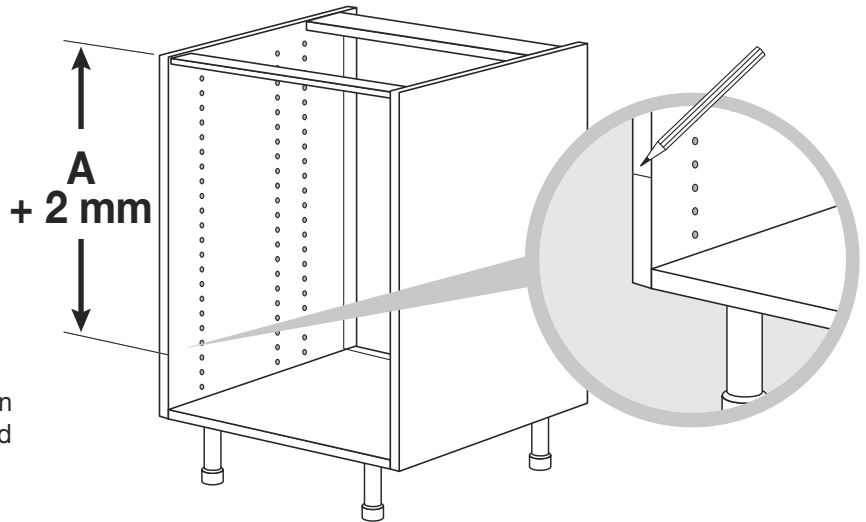
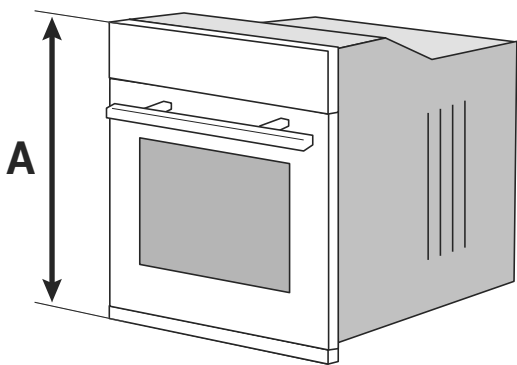

Pour positionner un four dans un élément bas, il faut retirer le fond du meuble.

Etape 2

Pose provisoire des équerres.

Au niveau du perçage 4 en partant du bas, visser des vis B avec rondelle dans la première et la troisième ligne de perçage de chaque flanc du caisson.

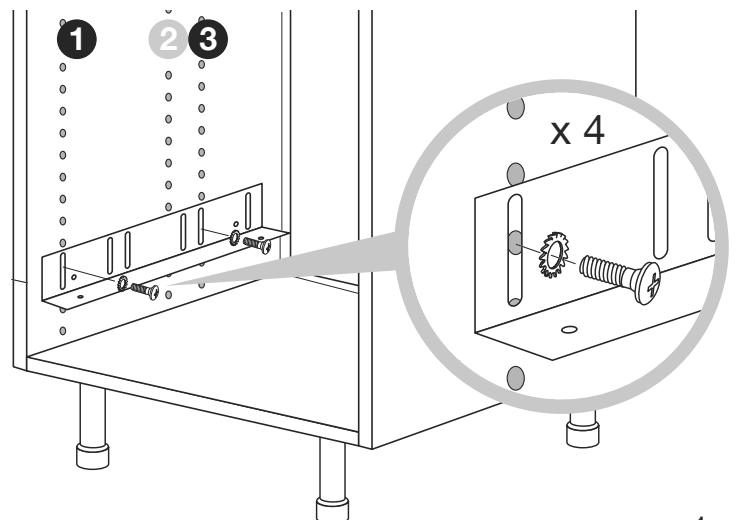
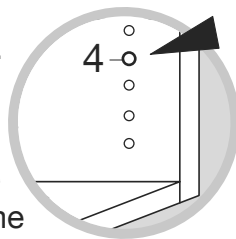

NE PAS SERRER LES VIS pour pouvoir ajuster les équerres.

Etape 3

A l'aide d'un niveau, ajuster les équerres en les faisant coulisser verticalement.

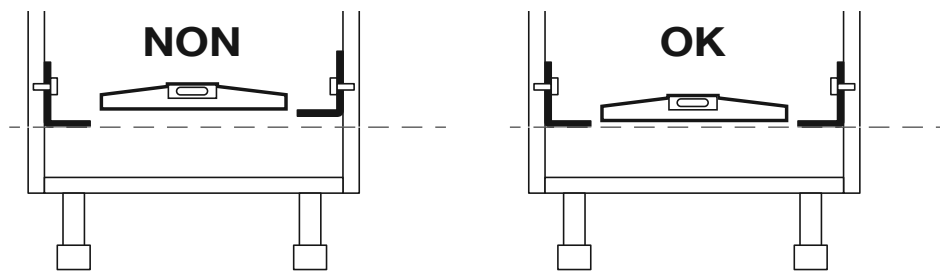

Etape 4

Serrer les vis B à fond et visser les 4 vis A autoperçantes dans le flanc du caisson.

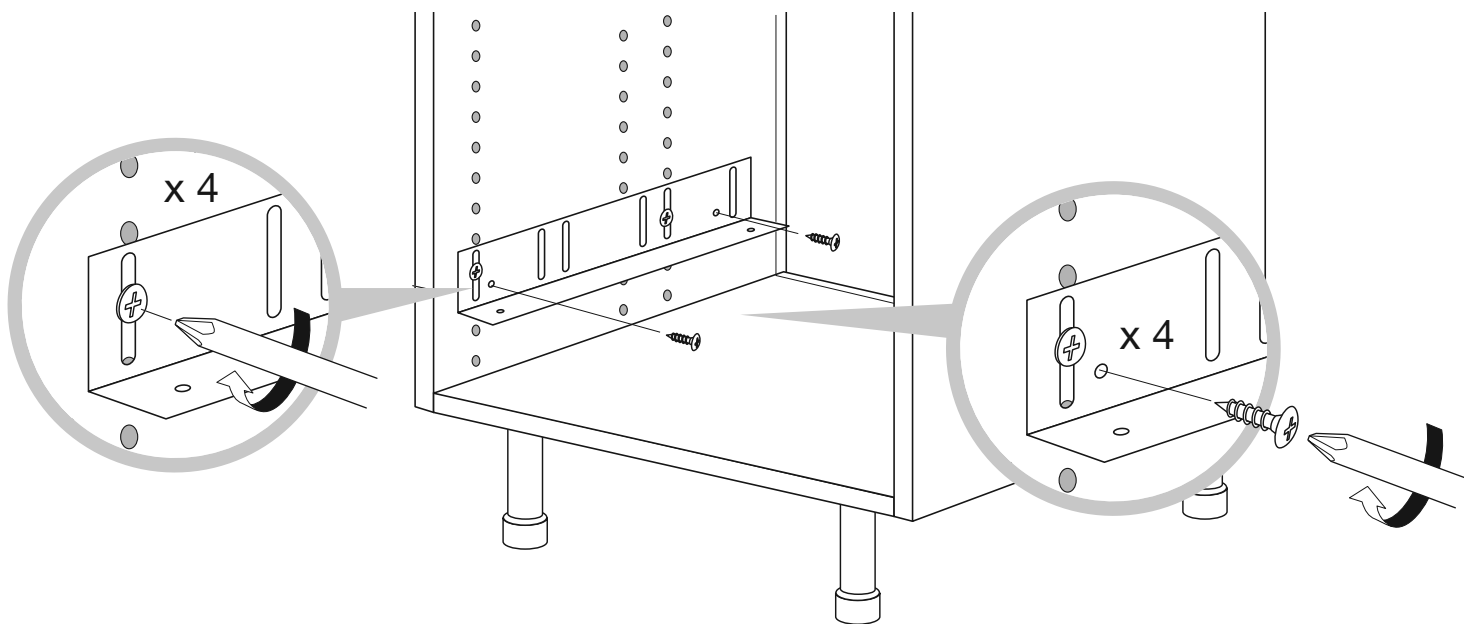

Etape 5

Ajustement du bandeau en hauteur.

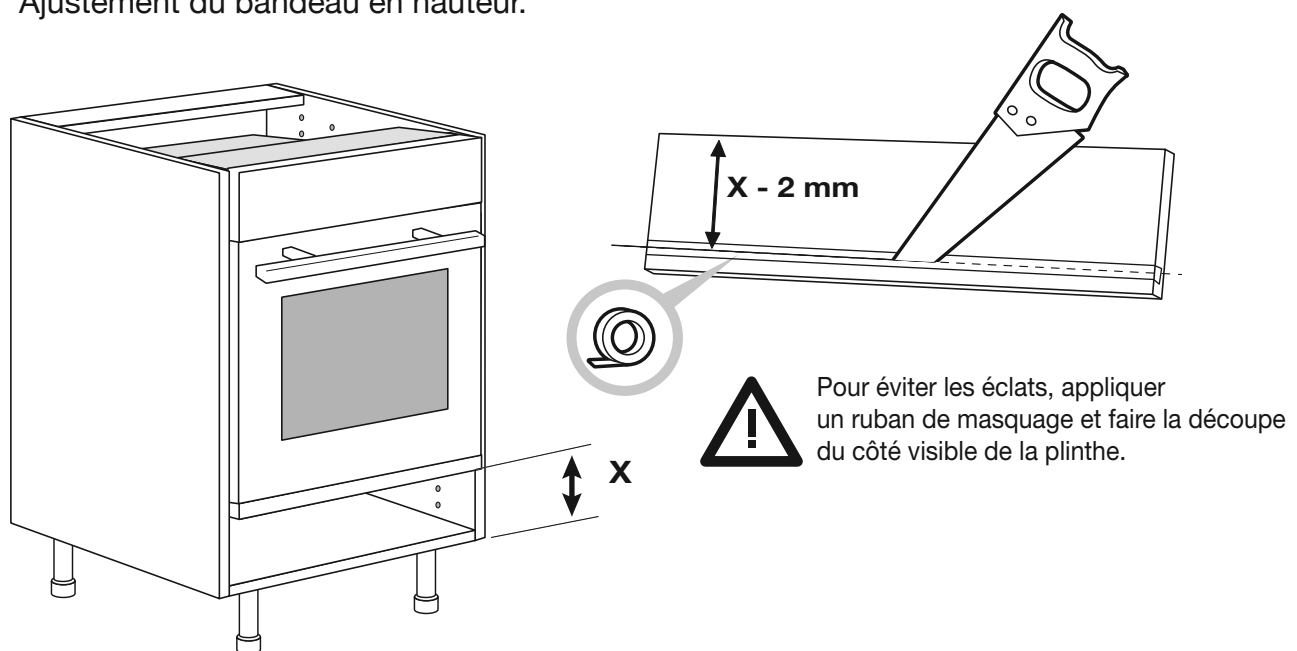

Etape 6

Pose des clips sur le bandeau.

A = 23,5 mm

B = 45 mm

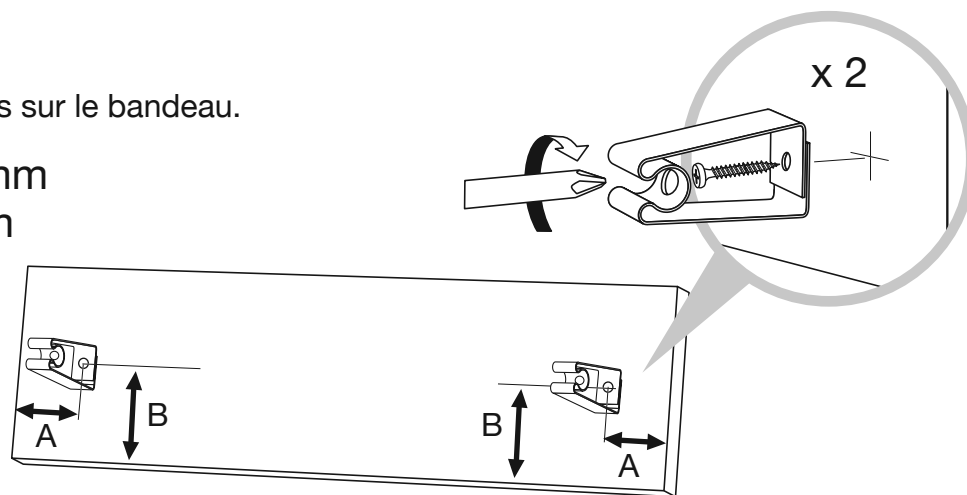

Etape 7

Pose des pivots sur le caisson.

Visser les pivots directement dans le premier perçage en partant du bas dans la ligne de perçage (située à 37 mm du bord) de chaque côté du caisson.

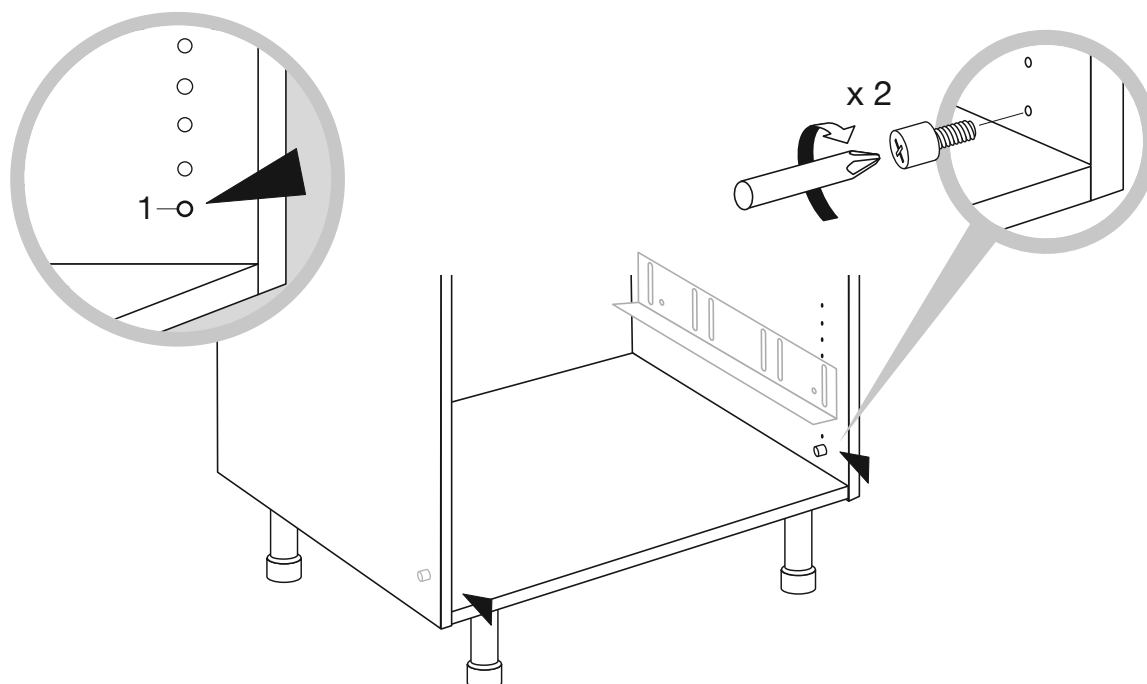

Etape 8

Poser le bandeau en le clipsant sur les pivots.

