

Fissaggio Lavello SottoTop per Modelli codice :
Unde-rmount installation for Models code :
ON4110ST - ON5610ST - ON6010ST - ON7610ST

SEZIONE TRASVERSALE - SIDE SECTION VIEW

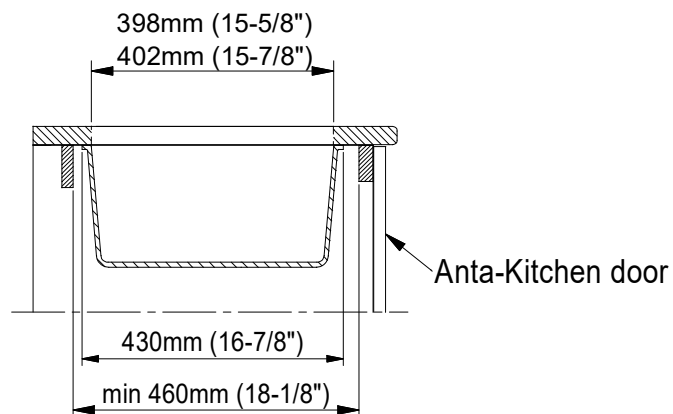

CABINET BACK

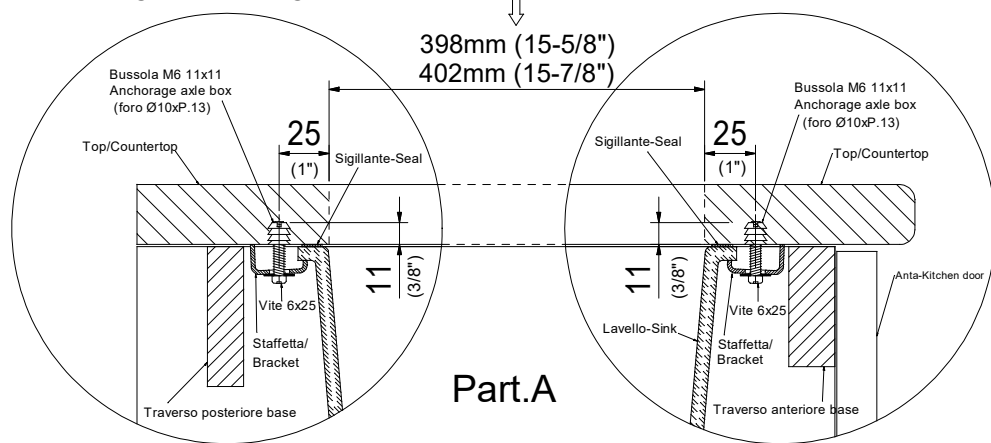

PARTICOLARI SEZIONI TRASVERSALI
SIDE SECTION VIEW DETAILS

Fissare il bordo posteriore al top con le
 tre staffette in dotazione e le viti 6x25

Fasten the 3 mounting brackets
 with the 6x25 screws

Fissare il bordo anteriore al top con le
 tre staffette in dotazione e le viti 6x25

Fasten the 3 mounting brackets
 with the 6x25 screws

FISSAGGIO SOTTOTOP CON STAFFETTE E VITI (Vedi Part. A)
UNDER-MOUNT WITH MOUNTING BRACKETS AND SCREWS (Part. A)

Foro su top L.338 x P.398mm
 Countertop hole W.15 -1/4" x H.15-5/8"

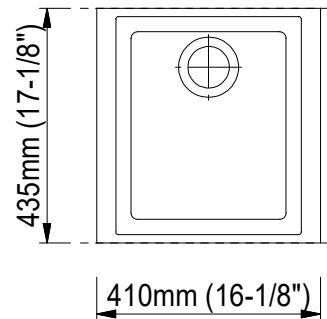

Foro su top L.488 x P.398mm
 Countertop hole W.19-1/4" H.15-5/8"

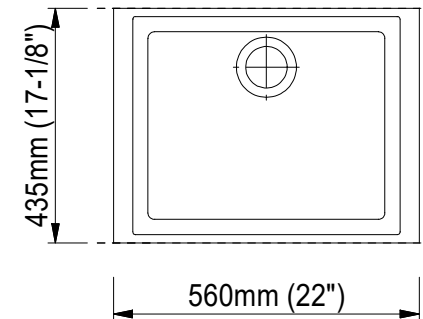

Foro su top L.528 x P.402mm
 Countertop hole W.20-3/4" H. 15-7/8"

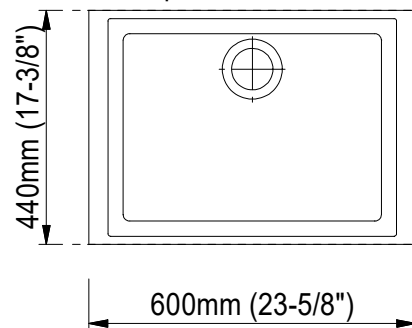

Foro su top L.688 x P.398mm
 Countertop hole W.27-1/8" H.15-5/8"

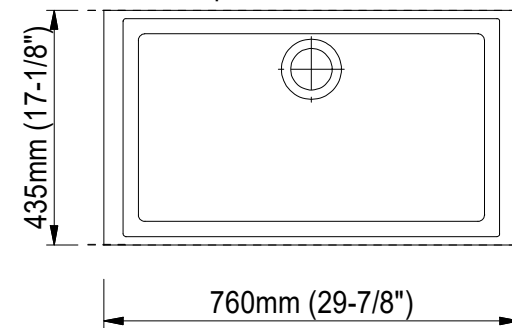

Ferramenta per fissaggio Sotto-Top
Under-mounting hardware

6 x

Bussola M6 11x11
 Anchorage axle box M6 11x11

6 x

Staffetta sotto/top
 Undermount bracket

6 x

Vite 6x25
 Screw 6x25

6 x

Dadi M6
 Nuts M6